

专利产品

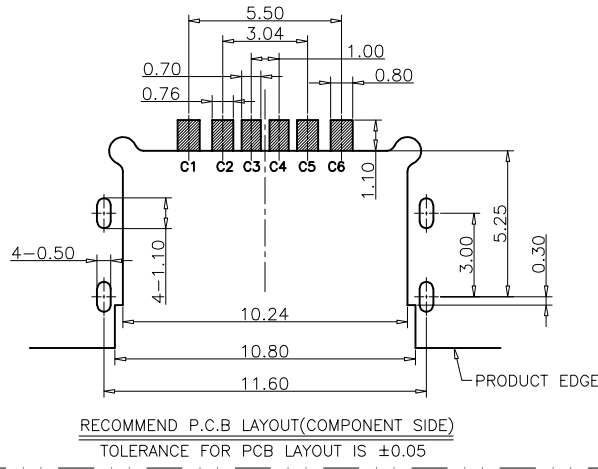

REV.	ECN	DESCRIPTION	MDF'D	DATE
A0		新订图面	Lee	2019.11.13

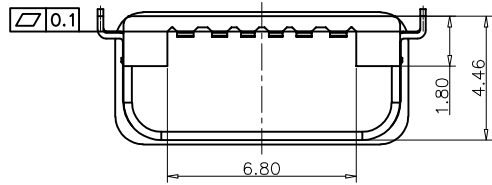
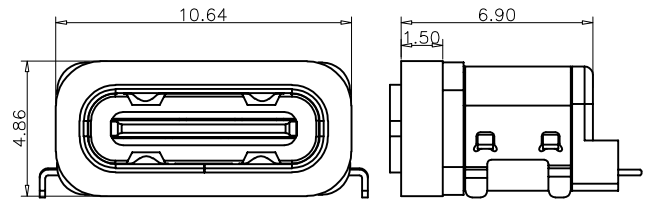

加防水圈示意图

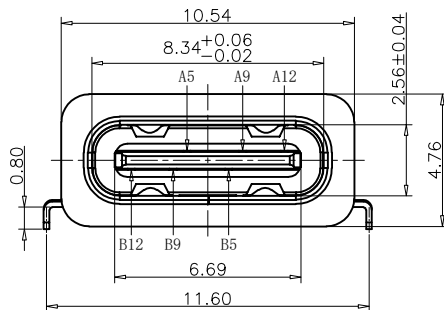
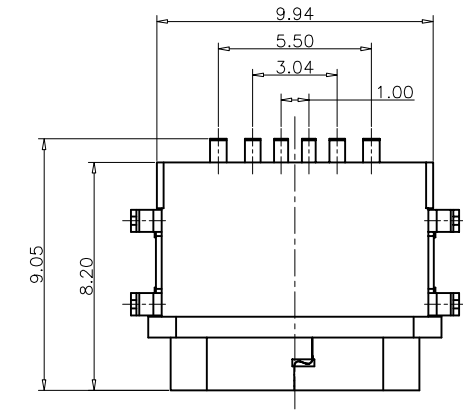
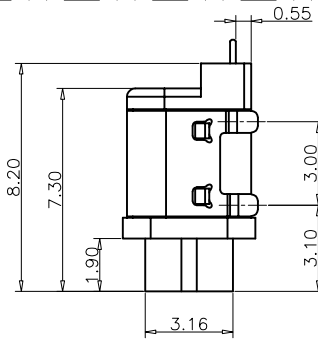
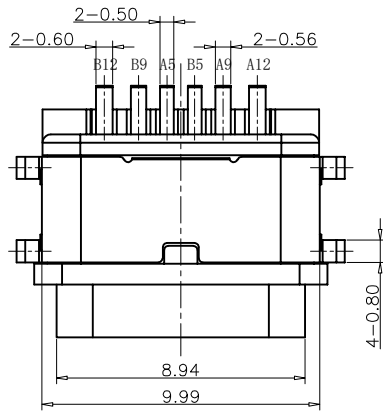

NOTES:

SPECIFICATION:

- CURRENT RATING: 3.0A MAX
- VOLTAGE: 100 VAC
- TEMPERATURE RANGE: -30°C~+85°C
- CONTACT RESISTANCE: 40 MILLIONHM MAX
- INSULATION RESISTANCE: 100 MEGOHMS MIN
- INSERTION FORCE: 5N~20N
- UNMATING FORCE: 8N~20N
- DURABILITY: 10000 CYCLES
- WATER PROOFNESS: THIS PRODUCT IS BASED ON IPX7.

TABLE:

NO	PART	Q'TY	Material
1	SHELL	1	STAINLESS STEEL, NI PLATED
2	CONTACT	6	COPPER STEEL, TIN/AU/NI PLATED
3	MID PLATE	1	STAINLESS STEEL, NO PLATING
4	1MD HOUSING	1	HIGH TEMPERATURE RESISTANT PLASTIC BLACK UL94 V-0
5	2MD HOUSING	1	HIGH TEMPERATURE RESISTANT PLASTIC BLACK UL94 V-0
6	SHIELDING PLATE	1	STAINLESS STEEL, NI PLATED

PIN ASSIGNMENT:

PIN NO	A1&B12	A4&B9	A5	B5	A9&B4	A12&B1
SIGNAL NAME	GND	VBUS	CC1	CC2	VBUS	GND
PCB PAD NO.	C1	C2	C3	C4	C5	C6

XB 东莞市溪榜电子有限公司
DONG GUAN XI BANG ELECTRONICS CO., LTD.

品名 (ITEM NO) TYPE C 6P 沉板防水母座A款(外壳4脚插板, 端子SMT)

料号 (PART NO) XB-ATCF-06-XXX

图号 (DWG NO) XB-TCF-039

页码 (SHEET) 1/1 单位 (UNIT): MM

版本 (REV) A0 比例 (SCALE) 1:1

日期 (DATE) 2021.11.13

设计 (DESIGN) Lee 未注公差 TOLERANCE UNSPECIFIED

审核 (CHECKED) L S W X.X ± 0.20

核准 (APPROVED) C J L X.XX ± 0.15

X.XXX ± 0.10

X° $\pm 5^\circ$

X.X° $\pm 2^\circ$

These drawings and specifications are the property of Dongguan Xibang Electronics Co., Ltd. and should not be copied. Without the prior written consent of Dongguan Xibang Electronics Co., Ltd., it shall not be copied or used in any way